

- In addition to routine checks for each use, PPE should regularly undergo a detailed inspection by a competent person. Petzl recommends an inspection every 12 months and after any exceptional event in the life of the product.
 - PPE inspection should be conducted with the manufacturer's Instructions for Use.
- Download the instructions at [PETZL.COM](https://www.petzl.com).

PROFESSIONAL HARNESSSES



1. Known product history

Any PPE showing questionable degradation should be quarantined, pending a detailed inspection.

The user should:

- Provide precise information on the usage conditions.
- Report any exceptional event regarding their PPE.

(Examples: fall or fall arrest, use or storage at extreme temperatures, modification outside manufacturer's facilities.)



2. Preliminary observations

Verify the presence and legibility of the serial number and the CE mark.

Please note: the serial number code on our products is evolving. Two types of code will coexist. See below for details on each serial number code.

Code A:

00 000 AA 0000

Year of manufacture
 Day of manufacture
 Name of Inspector
 Incrementation

Code B:

00 A 0000000 000

Year of manufacture
 Month of manufacture
 Batch number
 Incrementation



Verify that the product lifespan has not been exceeded.

Compare with a new product to verify there are no modifications or missing parts.

3. Checking the condition of the straps

- Check for cuts, swelling, damage and wear due, for example, to use, heat or chemicals. Check the waistbelt straps, leg loops, leg loop/waistbelt linkage and shoulder straps, if present. Be sure to check the areas hidden by the buckles.

- Check the condition of the safety stitching on both sides. Look for any threads that are loose, worn, or cut. Safety stitching is identified by thread of a different color or surface appearance than that of the webbing.

- Verify that hems are present on the strap ends.

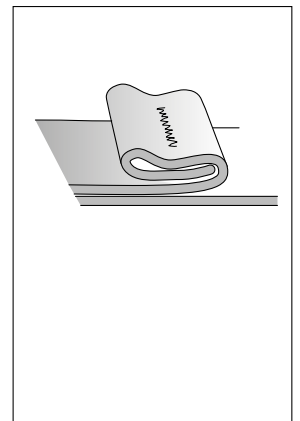
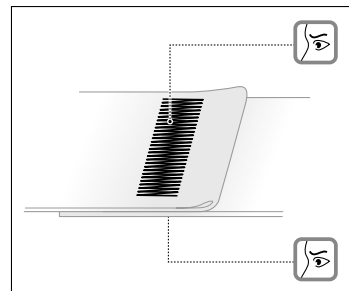
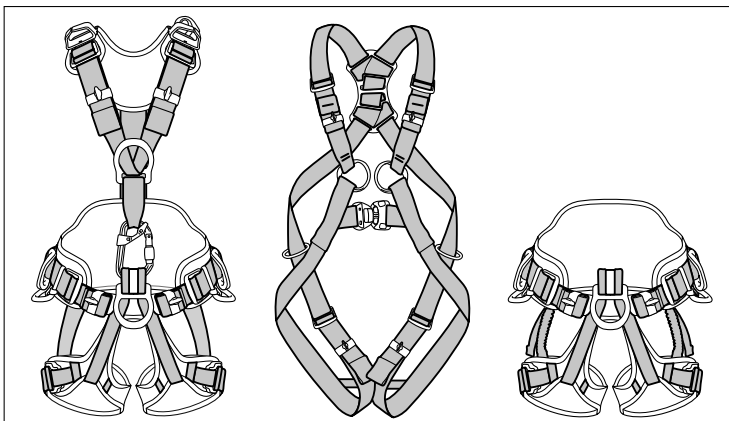

4. Checking the visual fall-arrest indicators

- On the international versions of the NAVAHO, NEWTON, AVAO, ASTRO, VOLT harnesses: check the dorsal visual fall-arrest indicator.

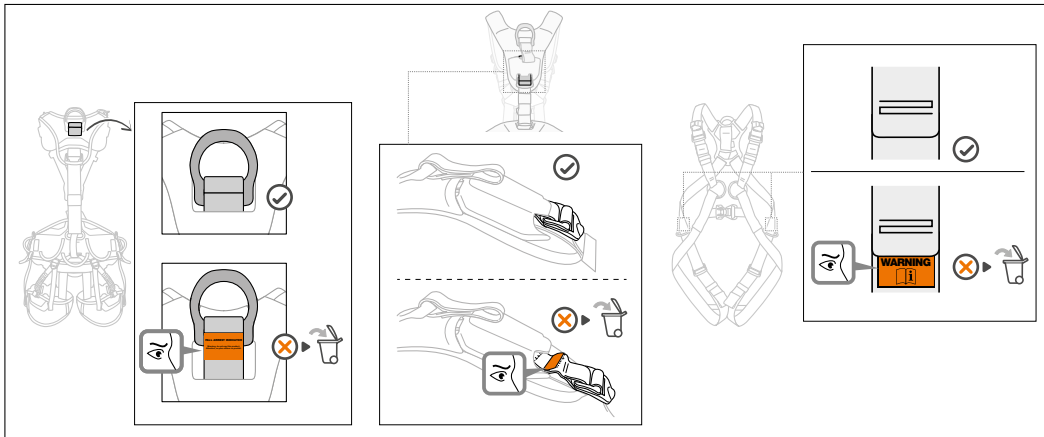

- On the European version of the VOLT harnesses: check the stitching on the LADDER CLIMB attachment-point strap.

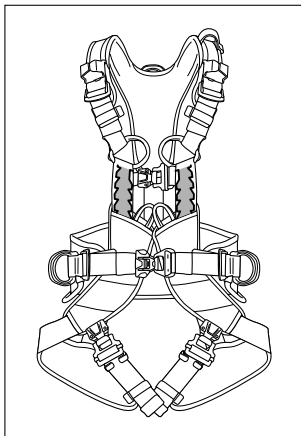

5. Checking the attachment points

- Check the condition of the metal attachment points (absence of any deformation, cracks, marks, wear, corrosion).

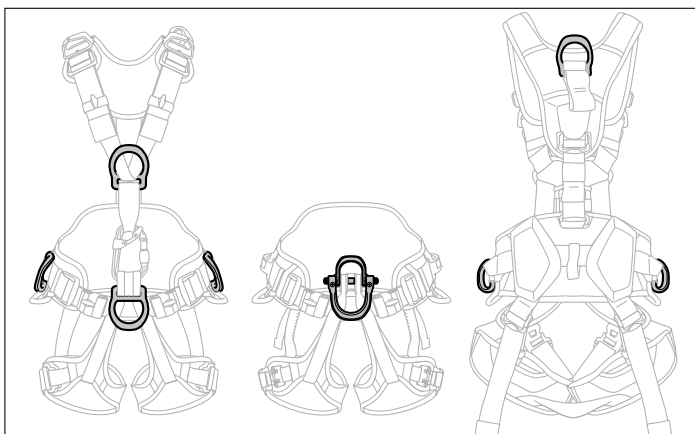

- Check the condition of the plastic attachment points (e.g. cuts, wear, tears).

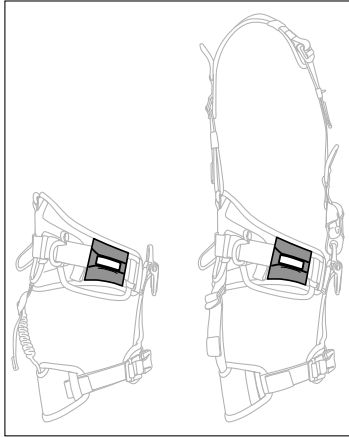

- Check the condition of the textile attachment points (e.g. cuts, wear, tears).

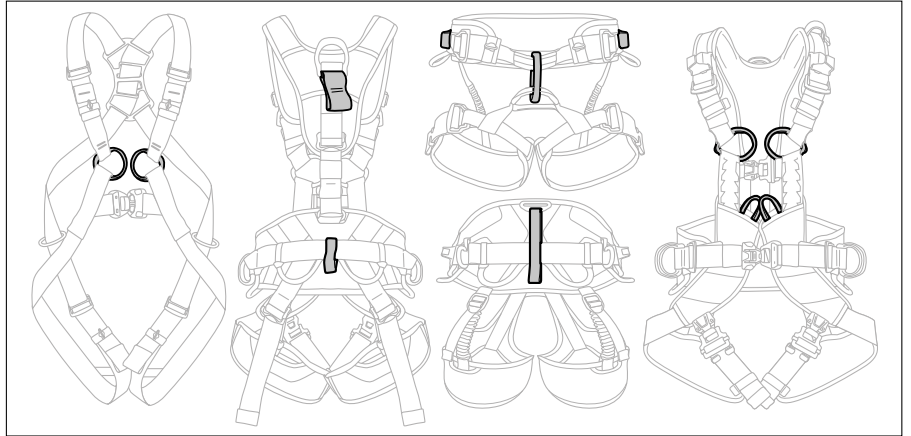

6. Checking the condition of the screws on the gated attachment point (on the ASTRO range)

- Inspect the screws:

Remove the screws to check their condition (deformation, cracks, corrosion, condition of the threads).

If you have any doubt about the condition of the screws, contact your after-sales service for replacement screws.

Verify the presence and condition of the threadlock and apply new threadlock if necessary.

If the screws do not have threadlock, apply threadlock to the screws or contact your after-sales service for replacement screws.

Re-install and tighten the screws to the correct torque, indicated in the Instructions for Use of the harness.

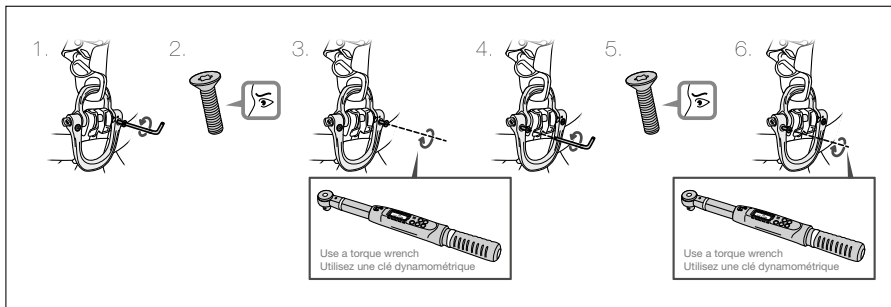

7. Checking the condition of the adjustment buckles

- Check the condition of the FAST adjustment buckles (absence of any deformation, cracks, marks, wear, corrosion).

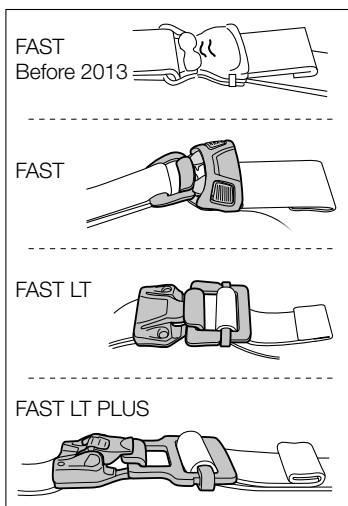

- Check the condition of the DOUBLEBACK adjustment buckles (absence of any deformation, cracks, marks, wear, corrosion).

- Check that the straps are correctly threaded, with no twists.

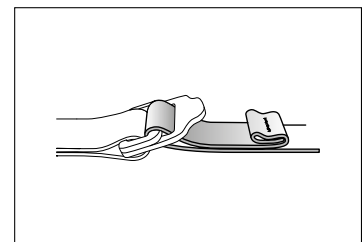
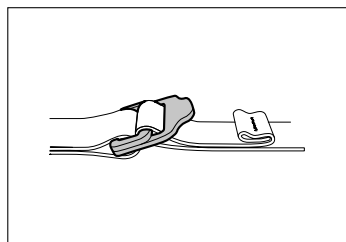

- Verify that the buckles function properly.

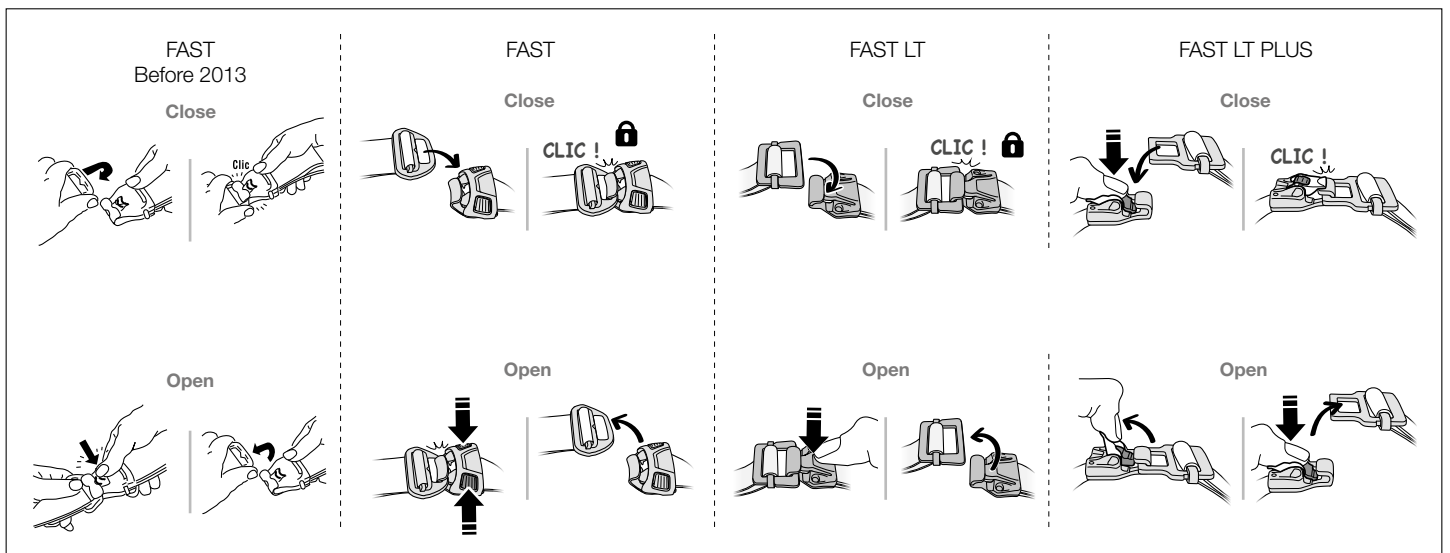
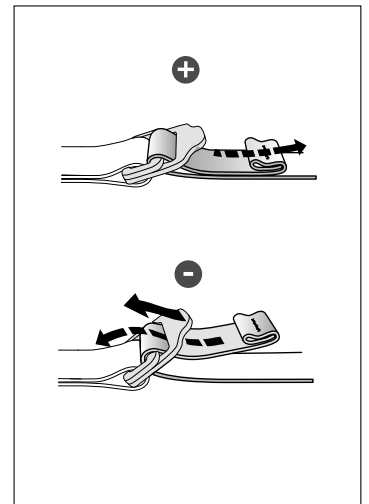
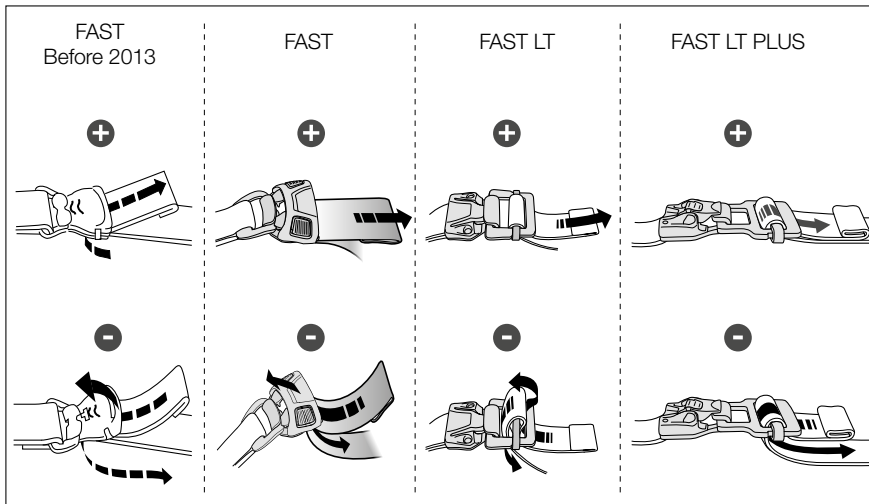

8. Checking the condition of the chest/sit harness connector (if any)

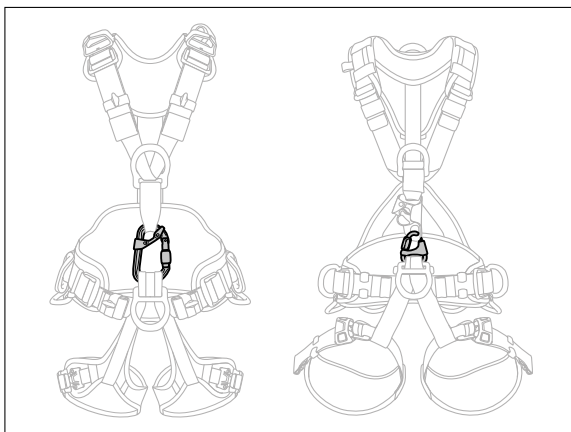

- If the harness features a chest/sit harness connector, make sure that it is present.
- Verify that the connector is the correct model and that it is correctly attached to the harness.
- For connector inspection, see the inspection form for your connector model at Petzl.com.

9. Checking the condition of the CROLL ascender (if any)

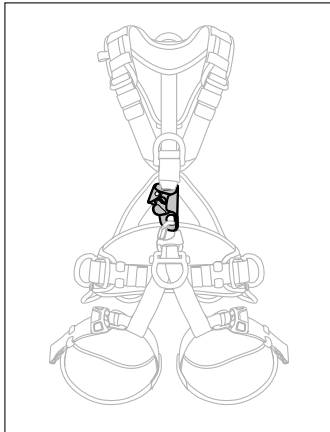

- For ascender inspection, see the inspection form for your ascender model at Petzl.com.

10. Checking the condition of the comfort parts

- Check the condition of the waist, leg and shoulder foams (e.g. cuts, wear, tears).

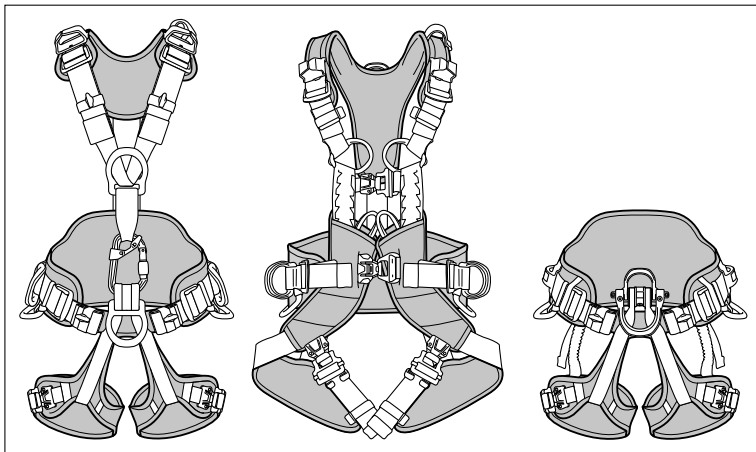

- Check the condition of the leg loop elastic bands (e.g. cuts, wear, tears).

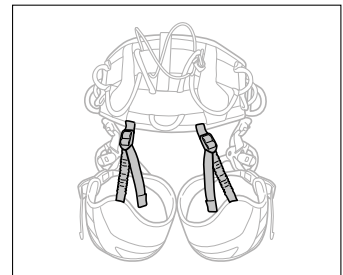

- Check the condition of the elastic and/or plastic keepers (e.g. cuts, wear, tears).

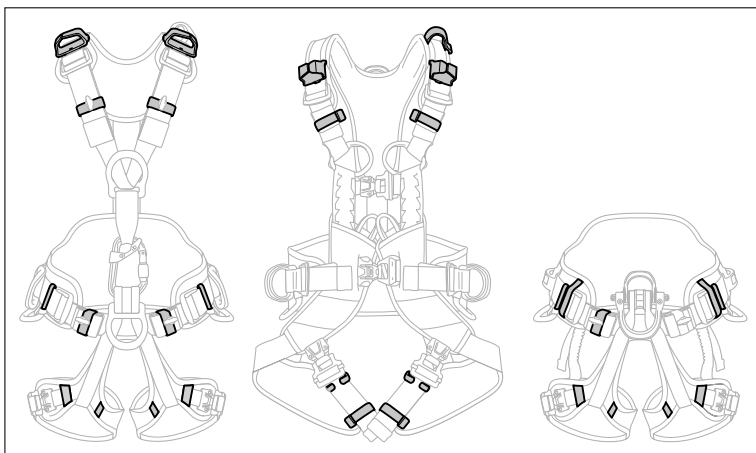

- Check the condition of the equipment loops (e.g. cuts, wear, tears).

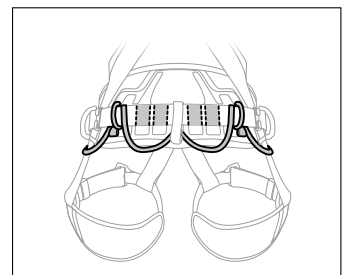

11. Special case for SEQUOIA/SEQUOIA SRT harnesses

- Check the condition of the textile attachment bridge (e.g. cuts, wear, tears). For attachment bridges made of rope: make sure the rope shows no signs of damage: e.g. cuts, burns, frayed strands, fuzzy areas, or signs of chemicals.

- Check the condition of the gated rings (absence of deformation, cracks, marks, wear, corrosion). Check the tightening torque of the screws using a torque wrench (the tightening torque is specified in the Instructions for Use of the equipment).

- Remove the screws to check the equipment separately, only if the condition of the equipment requires it. In this case, see the mounting instructions indicated in the Instructions for Use.

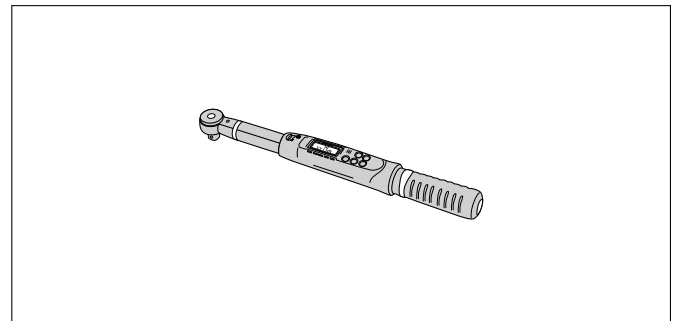
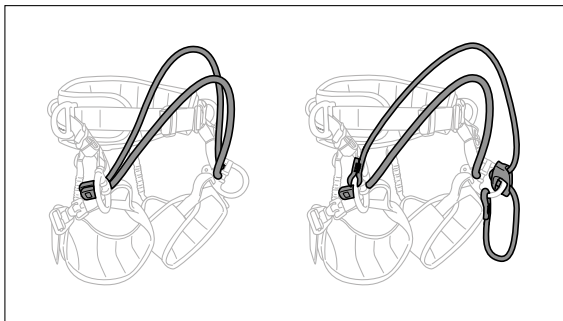
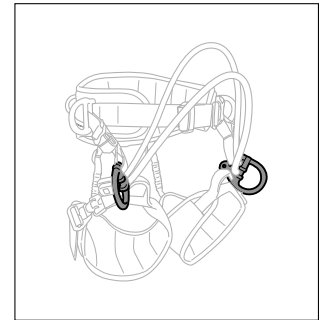
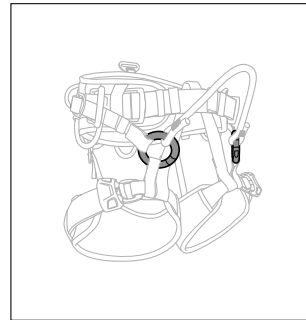
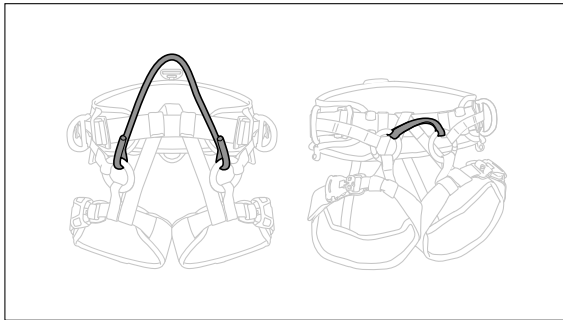

		SEQUOIA V1	SEQUOIA V2	SEQUOIA V3 (2019)
Mounting compatibility (certification not taken into account)				
Bridge v1 Strap		✓	✓	✓
Bridge v2 Rope with eye		✗	✓	✓
Bridge v3 (2019) With stop- per		✗	✗	✓
ADJUST bridge v2 and v3		✗	✓	✓

12. Special case: NEWTON HI-VIZ

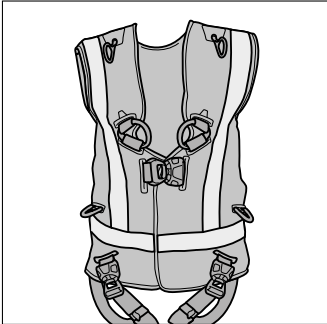

- On the HI-VIZ models, check the condition of the HI-VIZ vest and of the reflective bands (e.g. cuts, wear, fading).

13. Appendix: Examples of common issues to look for during inspection

- Onset of breakage of the waistbelt strap



- Cut equipment loop



- Damaged ASTRO screw



- Cut load-adjustment strap



- Damaged protective fabric



- Damaged protective fabric



- Reversed bar



- Snagged webbing

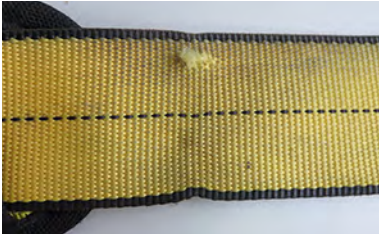

- Marking on webbing



- Cut webbing

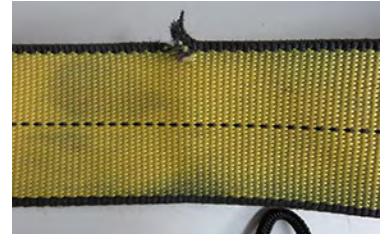

- Damaged webbing



- Damaged webbing



- Unstitched hem



- Damaged attachment point



- Fall indicator is visible



- Damaged safety stitching



- Damaged attachment point



- Damaged attachment point



- Damaged attachment point



- Worn out D-ring



- Broken buckle



- Corrosion



- Traces of paint



- Buckle not working



▶ Petzl contact